

NetworX NX-E Series Receiver Modules

Document Number: 466-1427 Rev. F
July 2001

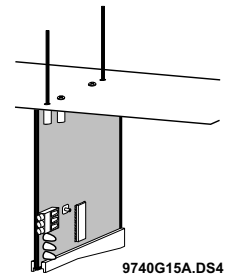

Installation Instructions

Product Summary

The NX-E Series Receiver Modules (8-zone NX-408E, 16-zone NX-416E, and 48-zone NX-448E) add wireless capabilities to the Caddx® NetworX NX-4, NX-6, NX-8, and NX-8E control panels. Adding a receiver module makes these control panels compatible with NX wireless transmitters and keychain touchpads (keyfobs).

The receiver modules mount inside the control panel cabinet and require just three wire connections for power and data communications to the motherboard.

Installation Guidelines

Use the following guidelines when installing receiver modules:

- ❑ Leave at least 10" above the control panel for the module's antennas.
- ❑ Avoid areas that are likely to expose the module to moisture.
- ❑ Avoid areas with excessive metal or electrical wiring, including furnace and utility rooms.

Installing the Receiver Module

The following steps describe mounting the circuit board edge guide standoff, securing the module to the cabinet, and inserting the antennas.

 **CAUTION**

You must be free of static electricity before handling circuit boards. Touch a bare metal surface or wear a grounding strap to discharge yourself.

1. After mounting the control panel cabinet, install the ground plane screws, washers, and nuts (included) in the holes on top of the cabinet (see Figure 1).

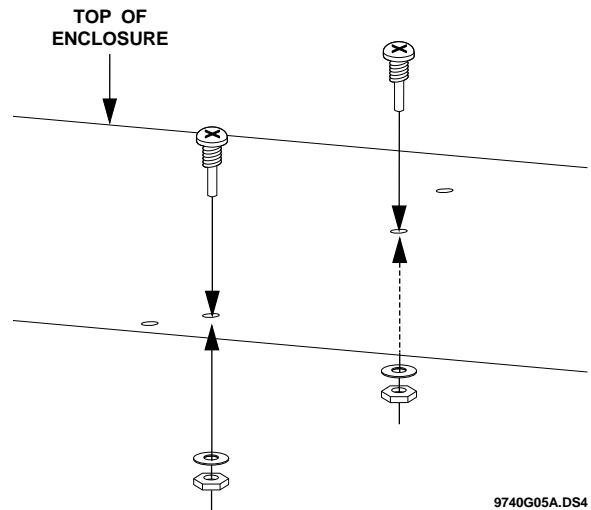

Figure 1. Installing the Ground Plane Screws, Washers, and Nuts

2. Install the circuit board edge guide standoff in the lower mounting hole, in either of the two spaces located just to the left of the motherboard (see Figure 2). Do not tighten the standoff at this time.

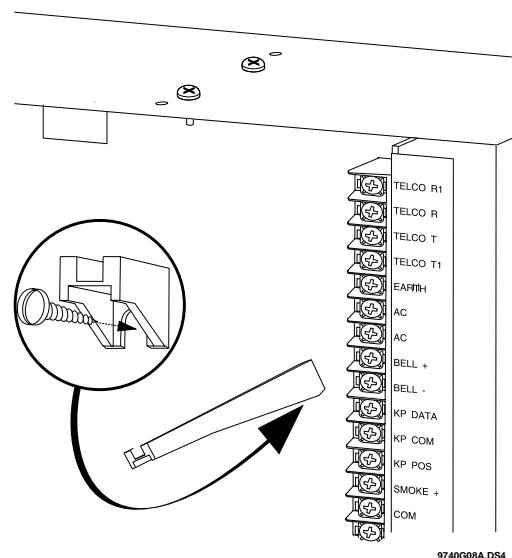
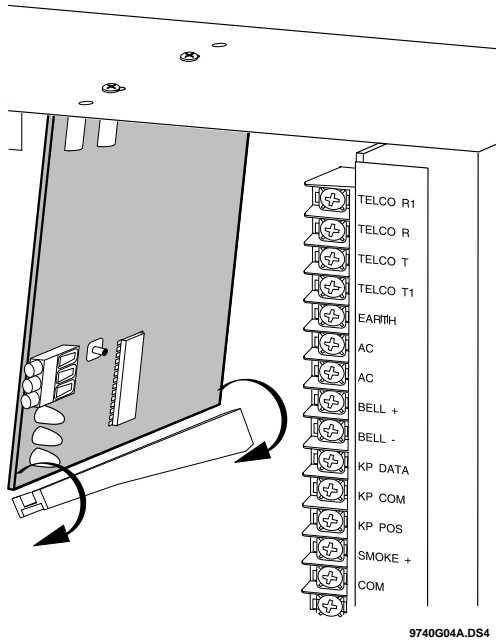

Figure 2. Installing the Circuit Board Edge Guide Standoff

3. Install the module into the cabinet by turning the stand-off sideways, then slide the module up onto the ground plane screw posts (see Figure 3).



9740G04A.DS4
Figure 3. Installing the Module into the Cabinet

4. Turn the standoff so the slot is facing up, insert the back corner of the module into the standoff slot, then press up at the front of the standoff and tighten the standoff screw.
5. Insert the antennas through the holes on top of the cabinet and into the module antenna sockets (see Figure 4).

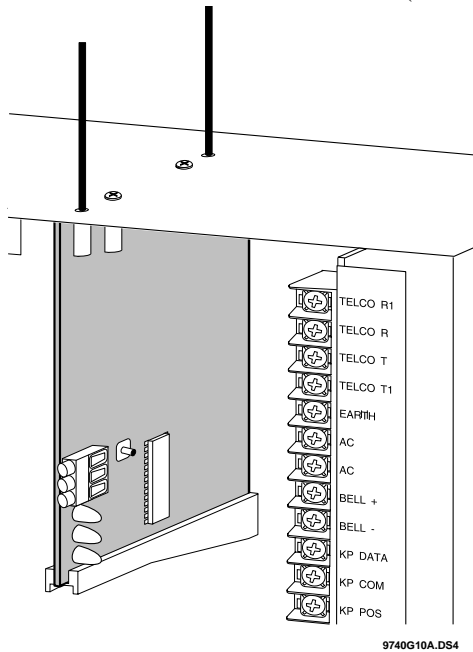

9740G10A.DS4
Figure 4. Inserting the Antennas

Wiring, Module Number DIP Switch Settings, and Power Up

The following steps describe wiring the module to the control panel, setting the module number DIP switches, and powering up the control panel.

1. Remove power (if applied) from the control panel.

CAUTION

To avoid possible equipment damage or personal injury, remove power from the control panel before making any wiring connections to the module.

2. Connect the module power and data terminals to the control panel power and data terminals using 22-gauge or larger, stranded wire (see Figure 5).

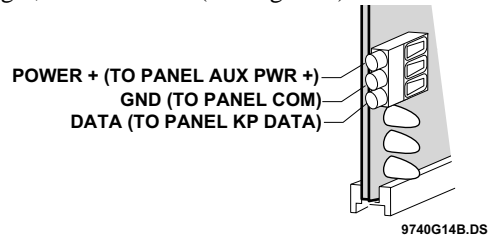

9740G14B.DS4
Figure 5. Wiring the Module Power and Data Terminals to the Panel Power and Data Terminals

3. Set the module DIP switches to the desired module number (see Table 1).

Table 1. Receiver Module Number Settings

<p>Module Number 32</p>	<p>Module Number 33</p>
<p>Module Number 34</p>	<p>Module Number 35</p>
<p>Module Number 36</p>	<p>Module Number 37</p>
<p>Module Number 38</p>	<p>Module Number 39</p>

4. Apply power to the control panel. The middle (red) LED on the module should start blinking. Table 2 describes the module’s status based on LED conditions.

Table 2. Module Status Conditions

LED	Module Status
Red-blinking	Normal data communication with the control panel.
Red-off	No data communication with control panel. Check wiring and power source.
Yellow-blinking	Receiving radio signals from wireless sensors.
Yellow-off	No radio signals currently being received.

Note
The red LED at the bottom of the module may emit a dim glow but is not used as an indicator and can be ignored.

Programming

This section describes the following programming steps:

- ❑ Determine Programming Settings—provides tables to record wireless transmitter and partition settings.
- ❑ Enroll the Module—sets up the module to be supervised by the control panel.
- ❑ Program the Module—puts the module into program so you can program zone bank settings, transmitters, and enter the settings for transmitters and partitions.

Determine Programming Settings

When programming wireless transmitters into the module, there are various options and partitions you can set for each transmitter. These settings appear in segments of each programming location.

Use “Table 3: Module Programming Settings” on pages 3 - 7 to record zone assignments and settings. Be sure to circle the module type in the location column to help identify where each zone resides; RM = receiver module, HE = hardware expander, P = panel. This gives you all the programming information in one place and helps speed up the programming process.

Zone Locations 1 - 192

Zone locations 1 - 192 are not numbered in Table 3 since these locations vary depending on location 194—Receiver Zone Bank Setting (see page 8).

For example, if location 194 is set to 3, the first available location is 25. The total number of available locations is dependant on the zone limits for both the panel and receiver.

Note
The default settings shown for Segments 1 and 2 in the first zone location apply to all zone locations.

Special Settings for Door/Window Transmitters

Use the following guidelines when setting features 4 and 5 for door/window transmitters and wireless smoke detectors.

- ❑ Feature 4—Input Option 1

For door/window transmitters, turn on this feature to disable the transmitter’s internal reed switches.

For wireless smoke detectors with tamper switches, turn on this feature to enable the tamper feature.

Note
Feature 4—Input Option 1, must be off (disabled) when using wireless smoke detectors without tamper switches.

- ❑ Feature 5—Input Option 2

For door/window transmitters that use a normally open external contact, leave this feature off (N/O).

For door/window transmitters that use a normally closed external contact, turn this feature on (N/C).

Light and Star Buttons on 4-Button Keyfobs

When using 4-button keyfobs, turning on Input Option 1 (feature 4) changes the light button to Keyfob Function 1. Turning on Input Option 2 (feature 5) changes the star button to Keyfob Function 2. These functions can be used to control relays, outputs, or X-10 devices.

Table 3. Module Programming Settings

Location	Segment 1	Segment 2
0 Transmitter to be programmed)	None	None
Zone ____ Assigned to module # ____. RM HE P	1 - Enable sensor <input type="checkbox"/> (default = off) 2 - Supervised <input type="checkbox"/> (default = on) 3 - Fire supervision <input type="checkbox"/> (default = off) 4 - Input option 1 <input type="checkbox"/> (default = off) 5 - Input option 2 <input type="checkbox"/> (default = off) 6 - 8 Not used	Partition 1 keyfob <input type="checkbox"/> (default = on) Partition 2 keyfob <input type="checkbox"/> (default = off) Partition 3 keyfob <input type="checkbox"/> (default = off) Partition 4 keyfob <input type="checkbox"/> (default = off) Partition 5 keyfob <input type="checkbox"/> (default = off) Partition 6 keyfob <input type="checkbox"/> (default = off) Partition 7 keyfob <input type="checkbox"/> (default = off) Partition 8 keyfob <input type="checkbox"/> (default = off)

Table 3. Module Programming Settings (Continued)

Location	Segment 1	Segment 2
193 Receiver Options (All default off)	1 - Enable jam detect <input type="checkbox"/> 2 - Enable auto advance to next zone number <input type="checkbox"/> 3 - Keyfob user ID <input type="checkbox"/> (off = all keyfobs report as user 99; on = keyfob reports as learned zone #) 4 - Enable antenna tamper (Only selectable on Inter- national versions; reports as <i>box tamper</i>) <input type="checkbox"/> 5 - Enable case tamper <input type="checkbox"/> 6-8 Not used	None
194 Receiver Zone Bank Setting (Default = 0—set this before learn- ing any sen- sors. See step 5 under “To program the module.”)	Starting zone numbers by bank setting: 0 = 1 <input type="checkbox"/> 1 = 9 <input type="checkbox"/> 2 = 17 <input type="checkbox"/> 3 = 25 <input type="checkbox"/> 4 = 33 <input type="checkbox"/> 5 = 41 <input type="checkbox"/> 6 = 49 <input type="checkbox"/> 7 = 57 <input type="checkbox"/> 8 = 65 <input type="checkbox"/> 9 = 73 <input type="checkbox"/> 10 = 81 <input type="checkbox"/> 11 = 89 <input type="checkbox"/> 12 = 97 <input type="checkbox"/> 13 = 105 <input type="checkbox"/> 14 = 113 <input type="checkbox"/> 15 = 121 <input type="checkbox"/> 16 = 129 <input type="checkbox"/> 17 = 137 <input type="checkbox"/> 18 = 145 <input type="checkbox"/> 19 = 153 <input type="checkbox"/> 20 = 161 <input type="checkbox"/> 21 = 169 <input type="checkbox"/> 22 = 177 <input type="checkbox"/> 23 = 185 <input type="checkbox"/>	
195 Supervision Windows	1 - Normal ____ hrs. (0 - 255 hours; default = 24 hours) (Do not change Seg- ment 3 setting unless required. See step 9 under “Changing the Transmitter Supervi- sion Windows.”)	Fire ____ hrs. (0 - 255 hours; default = 4 hours) Segment 3 Transmitter Check- in Window ____ min (1 - 30 minutes, default = 40—dis- abled)

Table 3. Module Programming Settings (Continued)

Location	Segment 1	Segment 2
200 Number of rounds received from last transmitter learned	None	None

Programming the Module

This section describes programming guidelines, how to get the module into program mode and set receiver options, zone banks, supervision windows, and program transmitters into memory.

Programming Guidelines

- NX-4 and NX-6 control panels can have receivers added with zones that overlap those contained in the control panel. No hardwire expanders can be used.
- NX-8 control panels may have expansion zones (hardwire or wireless) set the same as those contained in the control panel. To do this you must disable the onboard control panel zones. All zone expansion modules must not overlap any blocks of 8 zones.
- All other control panels can have wireless zones added to any zone. If a hardwire input (on either the control panel or hardwire expander) is also present on the same zone as an enabled wireless zone, the wireless transmitter takes priority.

To program the module:

1. Enter [*] [8] at the keypad. The five function lights should start flashing.
2. Enter the “Go To Program Code” (factory default is 9 7 1 3). The service light should flash and the five function lights should change from flashing to on steady.
3. Enter [XX] [#], where [XX] is the DIP switch setting module number and [#] is the entry key. The Armed LED should turn on, indicating the control panel is waiting for a programming location entry.
4. For new installations, enter [9] [1] [0] [#] to load factory defaults and clear any unwanted information in memory before any further programming.
5. For new installations, set the receiver zone bank (Location 194) to determine the starting zone number for the specific receiver module. This must be set before learning sensors. The bank setting is based on the zone capabilities of both the receiver and the panel.
6. Enter [0] [#] to enter the sensor learning location. The Ready LED should turn on and the Armed LED should turn off.

- Enter [XXX] [*], where [XXX] is a zone number (1 through 192) and [*] is the entry key.

Notes

Three beeps from the keypad indicates an entry error. This occurs if you enter a transmitter number that is not within the module's zone block or if you try learning a sensor that is already learned into the module.

If you change your mind about your entry, terminate programming by entering [0] [#] [0] [*] and start over from step 6.

- Trip the desired transmitter (within 250 seconds) as described in Table 4. Listen for the 'ding dong' for confirmation.

Table 4. Tripping Transmitters for Learning

Transmitter	Action
Door/Window, Shock, Glass Guard, Freeze	Activate tamper switch by removing cover.
Door/Window with External Contact	Activate tamper switch by removing cover. (Note: Feature 4—Input Option 1, must be on.)
Recessed Door/Window	Activate tamper switch by removing circuit board until tamper switch is exposed.
Micro Door/Window	Slide the battery about half-way out of the battery holder, then back.
PIR	Activate tamper switch by removing back plate from PIR.
Smoke Detector	Press and hold the test button.
Heat Detector	Press, then release the tamper switch.
Fire Pull	Activate tamper switch by removing sensor cover.
Single Button Panic	Press and hold the button.
Dual Button Panic	Press and hold both buttons together.
Keyfobs	Press and hold the arm and disarm buttons together.
Repeater	Press, then release the tamper switch.

- Program remaining transmitters by repeating steps 5-7.
- Exit program mode by entering [EXIT] [EXIT].

Program Transmitter and Partition Settings

This section describes programming guidelines, how to change the supervision windows, and program the transmitter and partition settings using the information you entered in "Table 3: Module Programming Settings."

Changing the Transmitter Supervision Windows

Note

For UL Listed installations, the normal supervision window must be set to 24 hours and the fire supervision window must be set to 4 hours.

**CAUTION**

Do not set the normal or fire supervision windows to 1 hour. This causes false trouble reports from all learned wireless transmitters.

- Enter [*] [8] at the keypad. The five function lights should start flashing.
- Enter the "Go To Program Code" (factory default is 9 7 1 3). The service light should flash and the five function lights should change from flashing to on steady.
- Enter [XX] [#], where [XX] is the DIP switch setting module number and [#] is the entry key. The Armed LED should turn on, indicating the control panel is waiting for a programming location entry.
- Enter [195] [#] to enter location 195, segment 1.
- Enter the new normal supervision time (0 - 255).

Note
Choosing 0 sets the normal supervision window to 256 hours.
- Press [*] to save any changes and automatically enter segment 2.
- Enter the new fire supervision time (0 - 255).

Note
Choosing 0 sets the fire supervision window to 256 hours.
- Press [*] to save any changes and automatically enter segment 3.
- Enter new short supervision time (up to 30 minutes).

Note
Segment 3 is a short supervision window setting (up to 30 minutes) that prevents arming if a transmitter has not checked in within the set time. This applies only to specific countries outside the U.S. Check the control panel installation manual to determine if this setting is available. Entering a number higher than 30 (the default value is 40) disables the feature.
- Press [*] to save any changes. The panel is now waiting for the next location entry.

Note
Pressing [#] does not save changes to the current segment, but does save changes made in previous segments.
- Enter [EXIT] [EXIT] when all changes are completed.

Programming Transmitter and Partition Settings

1. Enter [*] [8] at the keypad. The five function lights should start flashing.
2. Enter the “Go To Program Code” (factory default is 9 7 1 3). The service light should flash and the five function lights should change from flashing to on steady.
3. Enter [XX] [#], where [XX] is the DIP switch setting module number and [#] is the entry key. The Armed LED should turn on, indicating the control panel is waiting for a programming location entry.
4. Enter [XX] [#] to enter a location. For example, enter [1] [#] to enter location 1, segment 1. The Armed LED should turn on and the zone LEDs display the binary data for the current settings.
or-- Enter [1] [#] [*] to enter location 1, segment 2.
5. Enter [X] [*], where [X] is the setting number (1 - 8) from Table 3 that corresponds to the desired feature or partition setting number and [*] is the entry key. The keypad displays the settings for that location and segment.
6. Press the keypad button that corresponds to the feature number you want changed. Lights corresponding to the feature number turn on or off each time the button is pressed. Lights that turn on indicate the feature is on, lights that turn off indicate the feature is off.
For example, turn on transmitter features 1 (Transmitter Enabled) and 4 (Input Option 1) by pressing [1] [4]. The 1 and 4 LEDs turn on to indicate the features are turned on and the Ready LED flashes to indicate the change request.
7. Press [*] to enter the changes and automatically advance to segment 2.
Note
Pressing [#] does not save changes to the current segment, but does save changes made in previous segments. Repeat steps 4 - 7 to re-enter and make changes to a location and segment.
8. Press the keypad button that corresponds to the partition number you want changed. Lights corresponding to the partition number turn on or off each time the button is pressed. Lights that turn on indicate the keyfob is active in that partition, lights that turn off indicate the keyfob is inactive.
9. Repeat steps 4 - 8 to continue programming transmitter partition settings.
10. Enter [EXIT] [EXIT] when finished.

Deleting Transmitters

The following steps describe how to delete transmitters from the module.

This procedure makes the module ignore a transmitter but does not remove transmitter identification from the module’s memory. The transmitter can be reactivated later or a new one can be learned into the zone.

1. Enter [*] [8] at the keypad. The five function lights should start flashing.

2. Enter the “Go To Program Code” (factory default is 9 7 1 3). The service light should flash and the five function lights should change from flashing to on steady.
3. Enter [XX] [#], where [XX] is the DIP switch setting module number and [#] is the entry key. The Armed LED should turn on, indicating the control panel is waiting for a programming location entry.
4. Enter [XX] [#] to enter the zone location to be deleted. The Armed LED should turn on and the zone LEDs display the binary data for the current settings.
5. Change transmitter feature 1 (Transmitter Enabled) by pressing [1]. The 1 LED turns off to indicate the feature change and the Ready LED flashes to indicate the change request.
6. Enter [*] [#]. The Ready LED stops flashing, indicating the new settings are stored in memory and the system automatically exits from that location.
7. Continue deleting transmitters by entering the desired locations and segments in steps 4 through 6.
8. Enter [9] [1] [0] [#] to delete all transmitters and load factory defaults.
9. Enter [EXIT] [EXIT] when finished.

Testing Wireless Transmitters

Test all transmitters to verify correct programming and operation by following the “Walk Test” instructions in the specific control panel installation manual.

Troubleshooting

Any transmitters that consistently test below margin should be rotated in mounting position (90°, 180°, or 270°) and retested.

If rotating the transmitter mounting position does not improve signal reception or is not practical, move the transmitter to different locations near the desired mounting area. Test each location until the transmitter consistently tests good, then mount the transmitter.

Specifications

Compatibility: NX-4, NX-6, NX-8, NX-8E control panels

Frequency: 319.5 MHz (NX-408E, NX-416E, & NX-448E)

433 MHz (NX-408E-I, NX-416E-I, &
NX-448E-I)

Required Power: 12.0 VDC (provided by panel)

Current Draw: 20 mA maximum

Operating Temperature Range: 32° to 120°F (0° to 49°C)

Storage Temperature: -30° to 120°F (-34° to 60°C)

Maximum Humidity: 90% relative humidity, non-
condensing

Dimensions: 4.65" (11.8 cm) x 3.20" (8.1 cm)

U.L. Listings

The NetworX NX-E Series Receiver Modules (60-904) are U.L. Listed for UL1023 Household Burglary, UL985 Household Fire, and are listed for use with the following U.L. Listed devices:

NX-451 Door/Window Sensor (60-670-95R)

NX-470 4-Button Keychain Touchpad (60-659-95R)

NX-475 Water-Resistant Pendant Panic Button (60-578)

NX-480 PIR Motion Sensor (60-639-95R)

NX-490 Wireless Smoke Sensor (60-506)

Notices

This device complies with FCC Rules Part 15. Operation is subject to the following two conditions:

1. This device may not cause harmful interference.
2. This device must accept any interference that may be received, including interference that may cause undesired operation.

Changes or modifications not expressly approved by Interlogix, Inc. can void the user's authority to operate the equipment.



SECURITY & LIFE SAFETY GROUP

CADDX | ISL | GSC | ITI | KALATEL | SENTRA

1420 NORTH MAIN STREET | Gladewater, TX | 75647 | 800-727-2339 | www.interlogixinc.com

©2001 Interlogix,™ Inc. Interlogix is a trademark of Interlogix, Inc. Caddx, and ITI are registered trademarks of Interlogix, Inc.